

Metallized Polycarbonate film capacitors

MKC 344

MKC RADIAL POTTED CAPACITORS

PITCH 10/15/22.5/27.5 mm

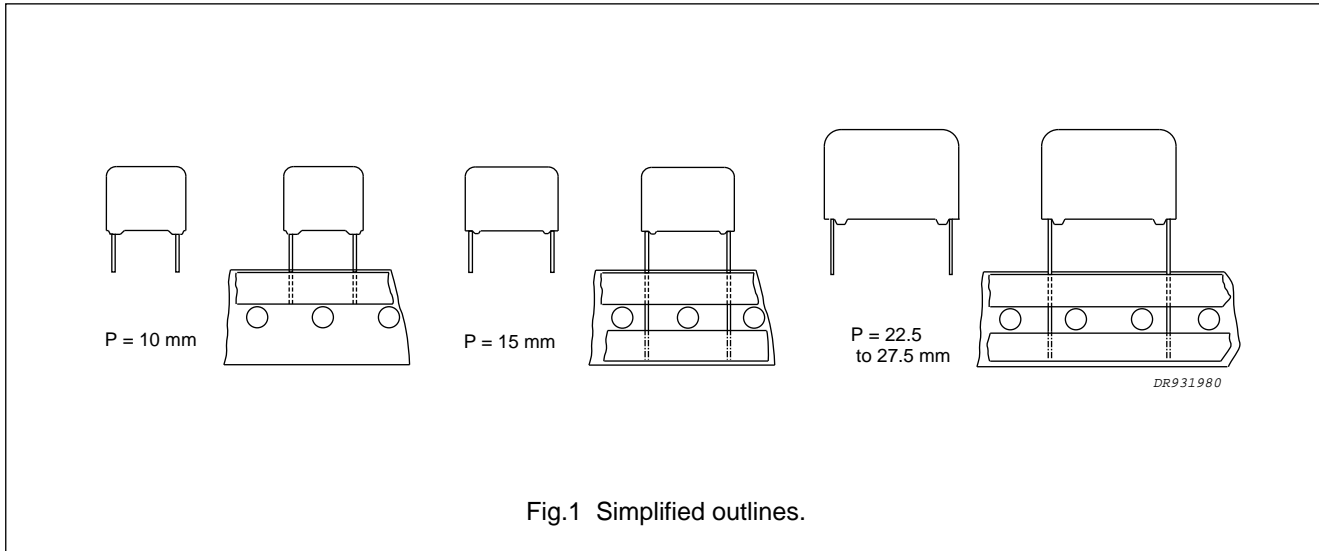

FEATURES

- 10 to 27.5 mm lead pitch
- Small dimensions for high density packaging
- Supplied loose in box and on tape.

APPLICATIONS

- In electronic circuits for blocking and coupling, bypass and energy reservoir applications.

QUICK REFERENCE DATA

DESCRIPTION	VALUE
Capacitance range (E12 series)	0.010 to 6.8 μ F
Capacitance tolerance	$\pm 10\%$; $\pm 5\%$
Rated voltage (DC)	100 V; 250 V; 400 V; 630V
Climatic category	55/100/56
Rated temperature	85 $^{\circ}$ C
Maximum application temperature	100 $^{\circ}$ C
Tangent of loss angle at 10 kHz	20×10^{-4}
Reference specification	IEC 384-6
Performance grade	grade 1 (long life)

Metallized Polycarbonate film capacitors

MKC 344

MKC 344 GENERAL DATA

PITCH 10/15/22.5/27.5 mm

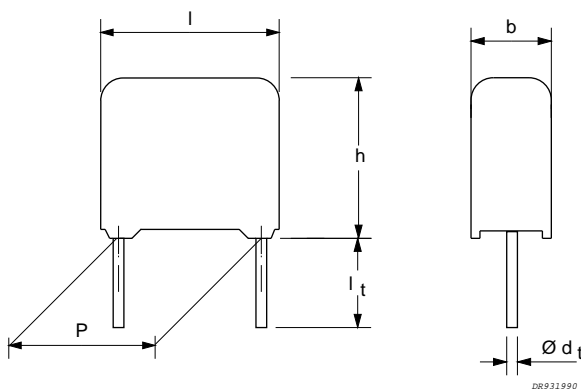

Fig.2 Outline.

Specific reference data for the 100 V DC capacitors

DESCRIPTION	VALUE		
	at 1 kHz	at 10 kHz	at 100 kHz
Tangent of loss angle:			
$C \leq 0.1 \mu\text{F}$	$\leq 30 \times 10^{-4}$	$\leq 60 \times 10^{-4}$	$\leq 130 \times 10^{-4}$
$0.1 \mu\text{F} < C \leq 1.0 \mu\text{F}$	$\leq 30 \times 10^{-4}$	$\leq 60 \times 10^{-4}$	–
$C > 1.0 \mu\text{F}$	$\leq 30 \times 10^{-4}$	$\leq 75 \times 10^{-4}$	–
Rated voltage pulse slope $(dU/dt)_R$ at U_{Rdc} :			
$P = 10.0 \text{ mm}$		60 V/ μs	
$P = 15.0 \text{ mm}$		26 V/ μs	
$P = 22.5 \text{ mm}$		12 V/ μs	
$P = 27.5 \text{ mm}$		9 V/ μs	
R between leads, for $C \leq 0.33 \mu\text{F}$		>15000 M Ω	
RC between leads, for $C > 0.33 \mu\text{F}$		>5000 s	

Available 100 V DC versions

PACKAGING	DIMENSIONS	C-tol	FIRST 9 DIGITS OF CATALOGUE NUMBER	ORDERING
Loose in box	$l_t = 5.0 \pm 1.0 \text{ mm}$	$\pm 10\%$	2222 344 21...	on request
		$\pm 5\%$	2222 344 22...	on request
Taped on reel	$H = 18.5 \text{ mm}$; note 1	$\pm 10\%$	2222 344 28...	on request
		$\pm 5\%$	2222 344 29...	on request

Note

1. H = in-tape height; for detailed specifications refer to this handbook, Chapter "Packaging".

Metallized Polycarbonate film capacitors

MKC 344

 $U_{Rdc} = 100 \text{ V}$; $U_{Rac} = 63 \text{ V}$

loose and taped

C (μF)	DIMENSIONS $b \times h \times l$ (mm)	MASS (g)	CATALOGUE NUMBER 2222 344 AND PACKAGING		
			LOOSE IN BOX; $l_t = 5.0 \pm 1.0 \text{ mm}$		REEL
			last 5 digits of catalogue number	SPQ	SPQ
			C-tol = $\pm 10\%$		
Pitch = $10.0 \pm 0.4 \text{ mm}$; $d_t = 0.60 \pm 0.06 \text{ mm}$					
0.082 0.1 0.12 0.15	4.0 × 10.0 × 12.5	0.7	21823	1000	1400
			21104		
			21124		
			21154		
0.18 0.22	5.0 × 11.0 × 12.5	0.9	21184	1000	1100
			21224		
Pitch = $15.0 \pm 0.4 \text{ mm}$; $d_t = 0.80 \pm 0.08 \text{ mm}$					
0.27 0.33 0.39 0.47	5.0 × 11.0 × 17.5	1.1	21274	1000	1100
			21334		
			21394		
			21474		
0.56 0.68	6.0 × 12.0 × 17.5	1.4	21564	1000	900
			21684		
0.82 1	7.0 × 13.5 × 17.5	1.8	21824	1000	800
			21105		
Pitch = $22.5 \pm 0.4 \text{ mm}$; $d_t = 0.80 \pm 0.08 \text{ mm}$					
1.2 1.5	6.0 × 15.5 × 26.0	2.8	21125	200	600
			21155		
1.8	7.0 × 16.5 × 26.0	4.3	21185	200	550
2.2 2.7	8.5 × 18.0 × 26.0	4.3	21225	200	450
		5.1	21275		
3.3	10.0 × 19.5 × 26.0	5.1	21335	200	350
Pitch = $27.5 \pm 0.4 \text{ mm}$; $d_t = 0.80 \pm 0.08 \text{ mm}$					
3.9 4.7	11.0 × 21.0 × 31.0	7.4	21395	100	300
			21475		
5.6 6.8	13.0 × 23.0 × 31.0	10.2	21565	100	250
			21685		

Metallized Polycarbonate film capacitors

MKC 344

MKC 344 GENERAL DATA

PITCH 10/15/22.5/27.5 mm

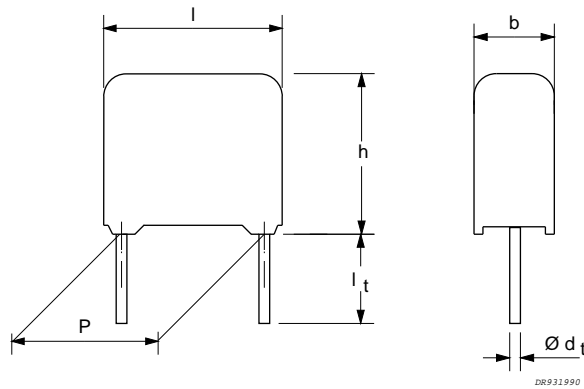

Fig.3 Outline.

Specific reference data for the 250 V DC capacitors

DESCRIPTION	VALUE		
	at 1 kHz	at 10 kHz	at 100 kHz
Tangent of loss angle:			
$C \leq 0.1 \mu\text{F}$	$\leq 30 \times 10^{-4}$	$\leq 60 \times 10^{-4}$	$\leq 130 \times 10^{-4}$
$0.1 \mu\text{F} < C \leq 1.0 \mu\text{F}$	$\leq 30 \times 10^{-4}$	$\leq 60 \times 10^{-4}$	–
$C > 1.0 \mu\text{F}$	$\leq 30 \times 10^{-4}$	$\leq 75 \times 10^{-4}$	–
Rated voltage pulse slope $(dU/dt)_R$ at U_{Rdc} :			
$P = 10.0 \text{ mm}$		90 V/ μs	
$P = 15.0 \text{ mm}$		36 V/ μs	
$P = 22.5 \text{ mm}$		16 V/ μs	
$P = 27.5 \text{ mm}$		14 V/ μs	
R between leads, for $C \leq 0.33 \mu\text{F}$		>30000 M Ω	
RC between leads, for $C > 0.33 \mu\text{F}$		>10000 s	

Available 250 V DC versions

PACKAGING	DIMENSIONS	C-tol	FIRST 9 DIGITS OF CATALOGUE NUMBER	ORDERING
Loose in box	$l_t = 5.0 \pm 1.0 \text{ mm}$	$\pm 10\%$	2222 344 45...	on request
		$\pm 5\%$	2222 344 43...	on request
Taped on reel	$H = 18.5 \text{ mm}$; note 1	$\pm 10\%$	2222 344 48...	on request
		$\pm 5\%$	2222 344 49...	on request

Note

1. H = in-tape height; for detailed specifications refer to this handbook, Chapter "Packaging".

Metallized Polycarbonate film capacitors

MKC 344

 $U_{Rdc} = 250 \text{ V}$; $U_{Rac} = 160 \text{ V}$

loose and taped

C (μF)	DIMENSIONS $b \times h \times l$ (mm)	MASS (g)	CATALOGUE NUMBER 2222 344 AND PACKAGING		
			LOOSE IN BOX; $l_t = 5.0 \pm 1.0 \text{ mm}$		REEL
			last 5 digits of catalogue number	SPQ	SPQ
			C-tol = $\pm 10\%$		
Pitch = $10.0 \pm 0.4 \text{ mm}$; $d_t = 0.60 \pm 0.06 \text{ mm}$					
0.039 0.047 0.056 0.068	4.0 × 10.0 × 12.5	0.7	45393	1000	1400
			45473		
			45563		
			45683		
Pitch = $15.0 \pm 0.4 \text{ mm}$; $d_t = 0.80 \pm 0.08 \text{ mm}$					
0.082 0.1 0.12 0.15	5.0 × 11.0 × 17.5	1.1	45823	1000	1100
			45104		
			45124		
			45154		
0.18 0.22	6.0 × 12.0 × 17.5	1.4	45184	1000	900
			45224		
0.27 0.33	7.0 × 13.5 × 17.5	1.8	45274	1000	800
			45334		
Pitch = $22.5 \pm 0.4 \text{ mm}$; $d_t = 0.80 \pm 0.08 \text{ mm}$					
0.39 0.47	6.0 × 15.5 × 26.0	2.8	45394	200	600
			45474		
0.56 0.68	7.0 × 16.5 × 26.0	3.5	45564	200	550
			45684		
0.82 1	8.5 × 18.0 × 26.0	5.1	45824	200	450
			45105		
Pitch = $27.5 \pm 0.4 \text{ mm}$; $d_t = 0.80 \pm 0.08 \text{ mm}$					
1.2	9.0 × 19.0 × 31.0	7.4	45125	100	400
1.5 1.8	11.0 × 21.0 × 31.0	7.4	45155	100	300
		10.2	45185		
2.2	13.0 × 23.0 × 31.0	10.2	45225	100	250

Metallized Polycarbonate film capacitors

MKC 344

MKC 344 GENERAL DATA

PITCH 10/15/22.5/27.5 mm

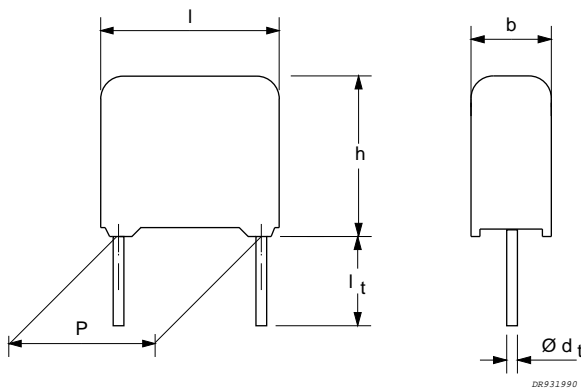

Fig.4 Outline.

Specific reference data for the 400 V DC capacitors

DESCRIPTION	VALUE		
	at 1 kHz	at 10 kHz	at 100 kHz
Tangent of loss angle: C ≤ 0.1 μF 0.1 μF < C ≤ 1.0 μF	≤30 × 10 ⁻⁴ ≤30 × 10 ⁻⁴	≤60 × 10 ⁻⁴ ≤60 × 10 ⁻⁴	≤130 × 10 ⁻⁴ -
Rated voltage pulse slope (dU/dt) _R at U _{Rdc} : P = 10.0 mm P = 15.0 mm P = 22.5 mm P = 27.5 mm	140 V/μs 60 V/μs 26 V/μs 22 V/μs		
R between leads, for C ≤ 0.33 μF	>30000 MΩ		
RC between leads, for C > 0.33 μF	>10000 s		

Available 400 V DC versions

PACKAGING	DIMENSIONS	C-tol	FIRST 9 DIGITS OF CATALOGUE NUMBER	ORDERING
Loose in box	$l_t = 5.0 \pm 1.0$ mm	±10%	2222 344 51...	on request
		±5%	2222 344 52...	on request
Taped on reel	H = 18.5 mm; note 1	±10%	2222 344 58...	on request
		±5%	2222 344 59...	on request

Note

1. H = in-tape height; for detailed specifications refer to this handbook, Chapter "Packaging".

Metallized Polycarbonate film capacitors

MKC 344

 $U_{Rdc} = 400 \text{ V}$; $U_{Rac} = 220 \text{ V}$

loose and taped

C (μF)	DIMENSIONS $b \times h \times l$ (mm)	MASS (g)	CATALOGUE NUMBER 2222 344 AND PACKAGING		
			LOOSE IN BOX; $l_t = 5.0 \pm 1.0 \text{ mm}$		REEL
			last 5 digits of catalogue number	SPQ	SPQ
			C-tol = $\pm 10\%$		
Pitch = $10.0 \pm 0.4 \text{ mm}$; $d_t = 0.60 \pm 0.06 \text{ mm}$					
0.01	4.0 × 10.0 × 12.5	0.7	51103	1000	1400
0.012			51123		
0.015			51153		
0.018			51183		
0.022			51223		
0.027			51273		
0.033			51333		
Pitch = $15.0 \pm 0.4 \text{ mm}$; $d_t = 0.80 \pm 0.08 \text{ mm}$					
0.039	5.0 × 11.0 × 17.5	1.1	51393	1000	1100
0.047			51473		
0.056			51563		
0.068			51683		
0.082	6.0 × 12.0 × 17.5	1.4	51823	1000	900
0.1			51104		
0.12	7.0 × 13.5 × 17.5	1.8	51124	1000	800
0.15			51154		
Pitch = $22.5 \pm 0.4 \text{ mm}$; $d_t = 0.80 \pm 0.08 \text{ mm}$					
0.18	6.0 × 15.5 × 26.0	2.8	51184	200	600
0.22			51224		
0.27	7.0 × 16.5 × 26.0	3.5	51274	200	550
0.33	8.5 × 18.0 × 26.0	3.5	51334	200	450
0.39		5.1	51394		
0.47	10.0 × 19.5 × 26.0	5.1	51474	200	350
Pitch = $27.5 \pm 0.4 \text{ mm}$; $d_t = 0.80 \pm 0.08 \text{ mm}$					
0.56	11.0 × 21.0 × 31.0	7.4	51564	100	300
0.68			51684		
0.82	13.0 × 23.0 × 31.0	10.2	51824	100	250
1			51105		

Metallized Polycarbonate film capacitors

MKC 344

MKC 344 GENERAL DATA

PITCH 10/15/22.5/27.5 mm

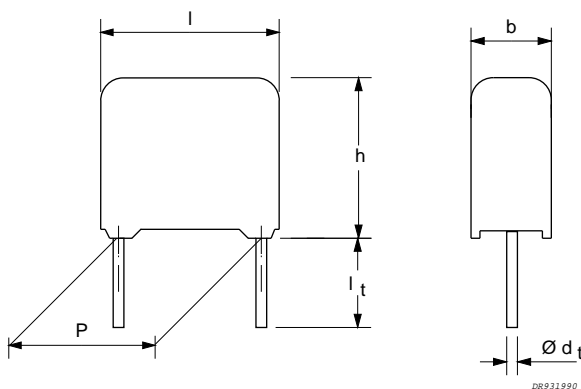

Fig.5 Outline.

Specific reference data for the 630 V DC capacitors

DESCRIPTION	VALUE		
	at 1 kHz	at 10 kHz	at 100 kHz
Tangent of loss angle: C ≤ 0.1 µF 0.1 µF < C ≤ 1.0 µF	≤30 × 10 ⁻⁴ ≤30 × 10 ⁻⁴	≤60 × 10 ⁻⁴ ≤60 × 10 ⁻⁴	≤130 × 10 ⁻⁴ -
Rated voltage pulse slope (dU/dt) _R at U _{Rdc} : P = 10.0 mm P = 15.0 mm P = 22.5 mm P = 27.5 mm	200 V/µs 90 V/µs 36 V/µs 30 V/µs		
R between leads, for C ≤ 0.33 µF	>30 000 MΩ		
RC between leads, for C > 0.33 µF	>10 000 s		

Available 630 V DC versions

PACKAGING	DIMENSIONS	C-tol	FIRST 9 DIGITS OF CATALOGUE NUMBER	ORDERING
Loose in box	l _t = 5.0 ±1.0 mm	±10%	2222 344 61...	on request
		±5%	2222 344 62...	on request
Taped on reel	H = 18.5 mm; note 1	±10%	2222 344 68...	on request
		±5%	2222 344 69...	on request

Note

1. H = in-tape height; for detailed specifications refer to this handbook, Chapter "Packaging".

Metallized Polycarbonate film capacitors

MKC 344

 $U_{Rdc} = 630 \text{ V}$; $U_{Rac} = 220 \text{ V}$

loose and taped

C (μF)	DIMENSIONS $b \times h \times l$ (mm)	MASS (g)	CATALOGUE NUMBER 2222 344 AND PACKAGING		
			LOOSE IN BOX; $l_t = 5.0 \pm 1.0 \text{ mm}$		REEL
			last 5 digits of catalogue number	SPQ	SPQ
			C-tol = $\pm 10\%$		
Pitch = $10.0 \pm 0.4 \text{ mm}$; $d_t = 0.60 \pm 0.06 \text{ mm}$					
0.01	$4.0 \times 10.0 \times 12.5$	0.7	61103	1000	1400
0.012	$5.0 \times 11.0 \times 12.5$	0.9	61123	1000	1100
0.015			61153		
0.018			61183		
0.022	$6.0 \times 12.0 \times 12.5$	1.0	61223	1000	900
Pitch = $15.0 \pm 0.4 \text{ mm}$; $d_t = 0.80 \pm 0.08 \text{ mm}$					
0.027	$5.0 \times 11.0 \times 17.5$	1.4	61273	1000	1100
0.033	$6.0 \times 12.0 \times 17.5$	1.4	61333	1000	900
0.039		1.8	61393		
0.047	$7.0 \times 13.5 \times 17.5$	1.8	61473	1000	800
0.056		2.6	61563		
0.068	$8.5 \times 15.0 \times 17.5$	2.6	61683	1000	650
Pitch = $22.5 \pm 0.4 \text{ mm}$; $d_t = 0.80 \pm 0.08 \text{ mm}$					
0.082	$7.0 \times 16.5 \times 26.0$	2.8	61823	200	550
0.1		3.5	61104		
0.12		3.5	61124		
0.15	$8.5 \times 18.0 \times 26.0$	3.5	61154	200	450
0.18	$10.0 \times 19.5 \times 26.0$	5.1	61184	200	350
0.22		5.1	61224		
Pitch = $27.5 \pm 0.4 \text{ mm}$; $d_t = 0.80 \pm 0.08 \text{ mm}$					
0.27	$11.0 \times 21.0 \times 31.0$	7.4	61274	100	300
0.33			61334		
0.39	$13.0 \times 23.0 \times 31.0$	10.2	61394	100	250
0.47			61474		

Metallized Polycarbonate film capacitors

MKC 344

CONSTRUCTION

Description

- Low-inductive wound cell of metallized polycarbonate (PC) film, potted with epoxy resin in a blue flame-retardant case
- Radial copper leads, solder-coated
- Small stand-off pips allow removal of solder flux etc. during cleaning of the printed-circuit board.

SPACE REQUIREMENTS ON PRINTED-CIRCUIT BOARD

The maximum length and width of film capacitors is shown in Fig.7:

- Eccentricity as in Fig.7. The maximum eccentricity is smaller than or equal to the lead diameter of the product concerned
- Product height with seating plane as given by "IEC 717" as reference: $h_{max} \leq h + 0.3 \text{ mm}$.

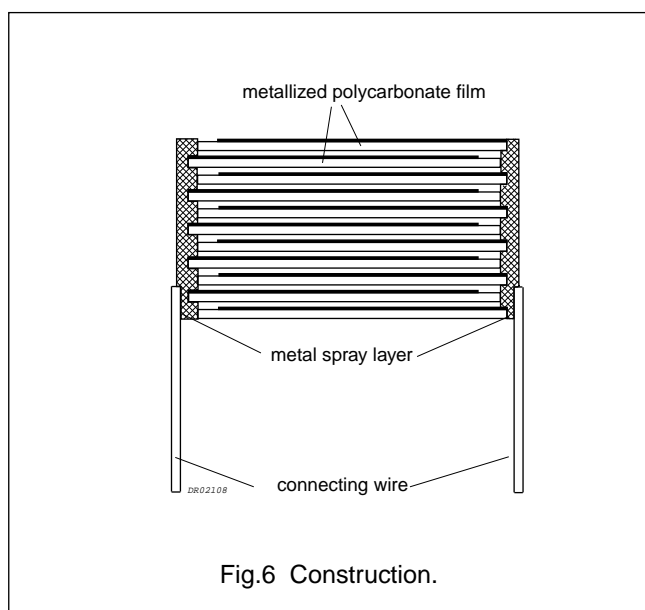

Fig.6 Construction.

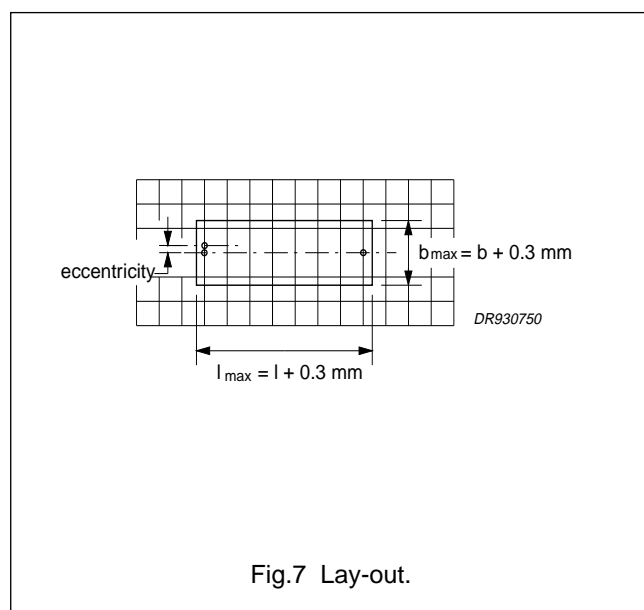

Fig.7 Lay-out.

Mounting

NORMAL USE

The capacitors are designed for mounting on printed-circuit boards. The capacitors packed in bandoliers are designed for mounting on printed-circuit boards by automatic insertion machines.

For detailed tape specifications refer to this handbook Chapter "Packaging".

SPECIFIC METHOD OF MOUNTING TO WITHSTAND VIBRATION AND SHOCK

It must be ensured that the stand-off pips are in good contact with the printed-circuit board:

- For pitches $\leq 15 \text{ mm}$ capacitors shall be mechanically fixed by the leads
- For larger pitches the capacitors shall be mounted in the same way and the body clamped.

RATINGS AND CHARACTERISTICS

Unless otherwise specified, all electrical values apply to an ambient free air temperature of $23 \pm 1 \text{ }^\circ\text{C}$, an atmospheric pressure of 86 to 106 kPa and a relative humidity of $50 \pm 2\%$.

For reference testing, a conditioning period shall be applied of 96 ± 4 hours by heating the products in a circulating air oven at the rated temperature and a relative humidity not exceeding 20%.

Metallized Polycarbonate film capacitors

MKC 344

Capacitance

All capacitance values are specified at 1 kHz.

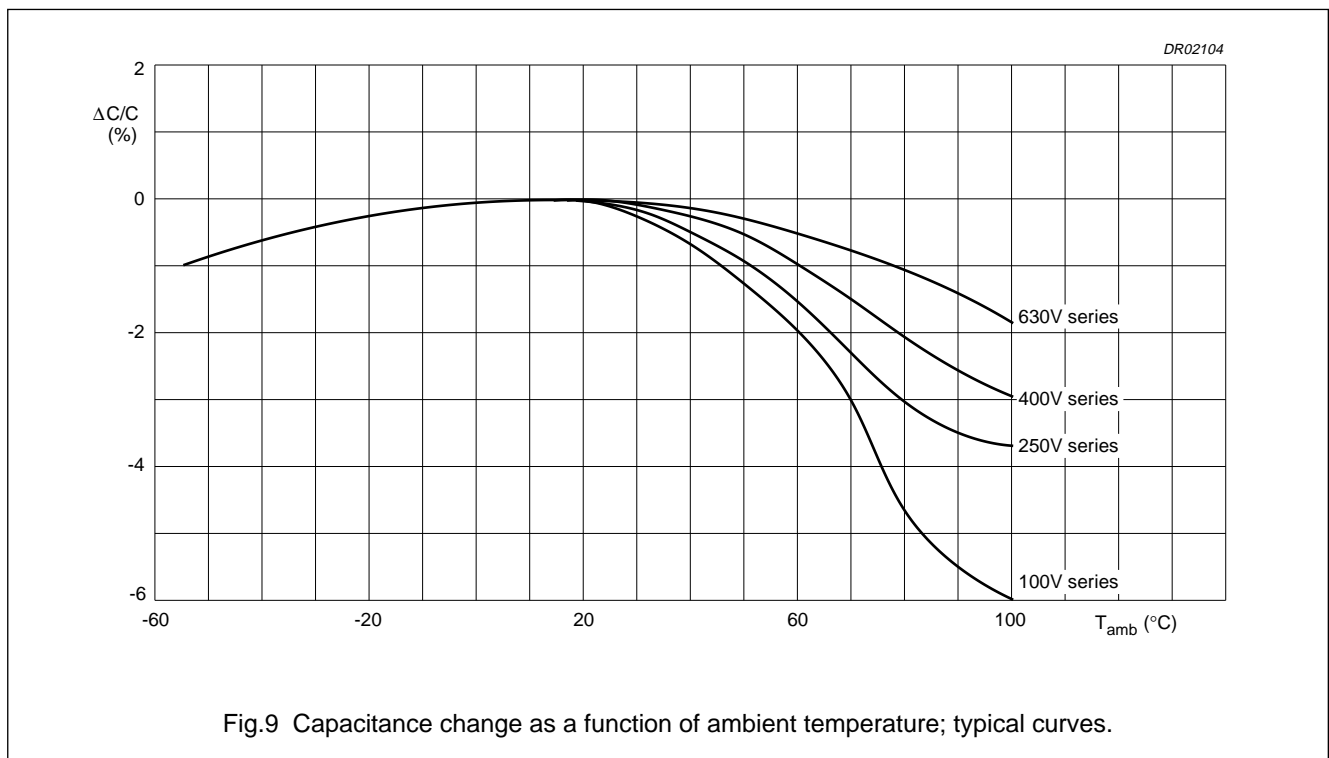
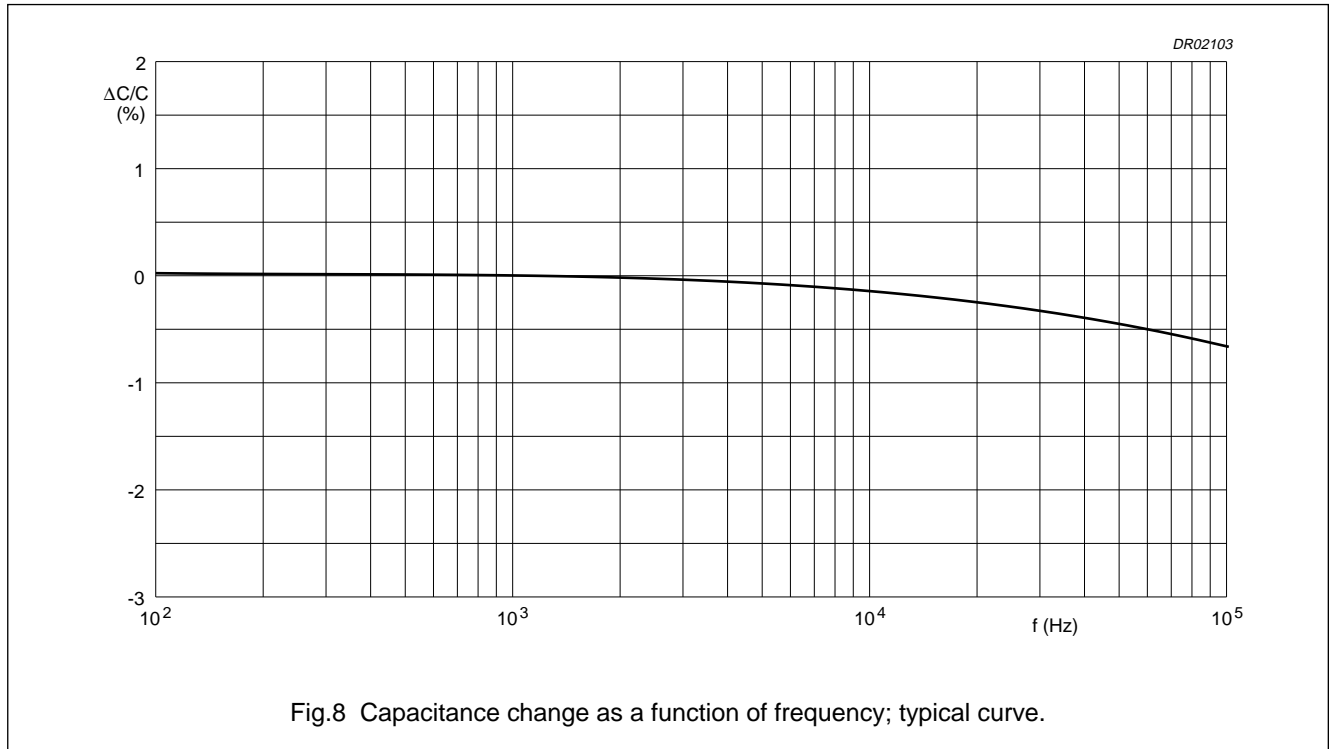

Metallized Polycarbonate film capacitors

MKC 344

Tangent of loss angle

CAPACITANCE	TANGENT OF LOSS ANGLE		
	at 1 kHz	at 10 kHz	at 100 kHz
$C \leq 0.1 \mu\text{F}$	$\leq 30 \times 10^{-4}$	$\leq 60 \times 10^{-4}$	$\leq 130 \times 10^{-4}$
$0.1 \mu\text{F} < C \leq 1 \mu\text{F}$	$\leq 30 \times 10^{-4}$	$\leq 60 \times 10^{-4}$	–
$C > 1 \mu\text{F}$	$\leq 30 \times 10^{-4}$	$\leq 75 \times 10^{-4}$	–

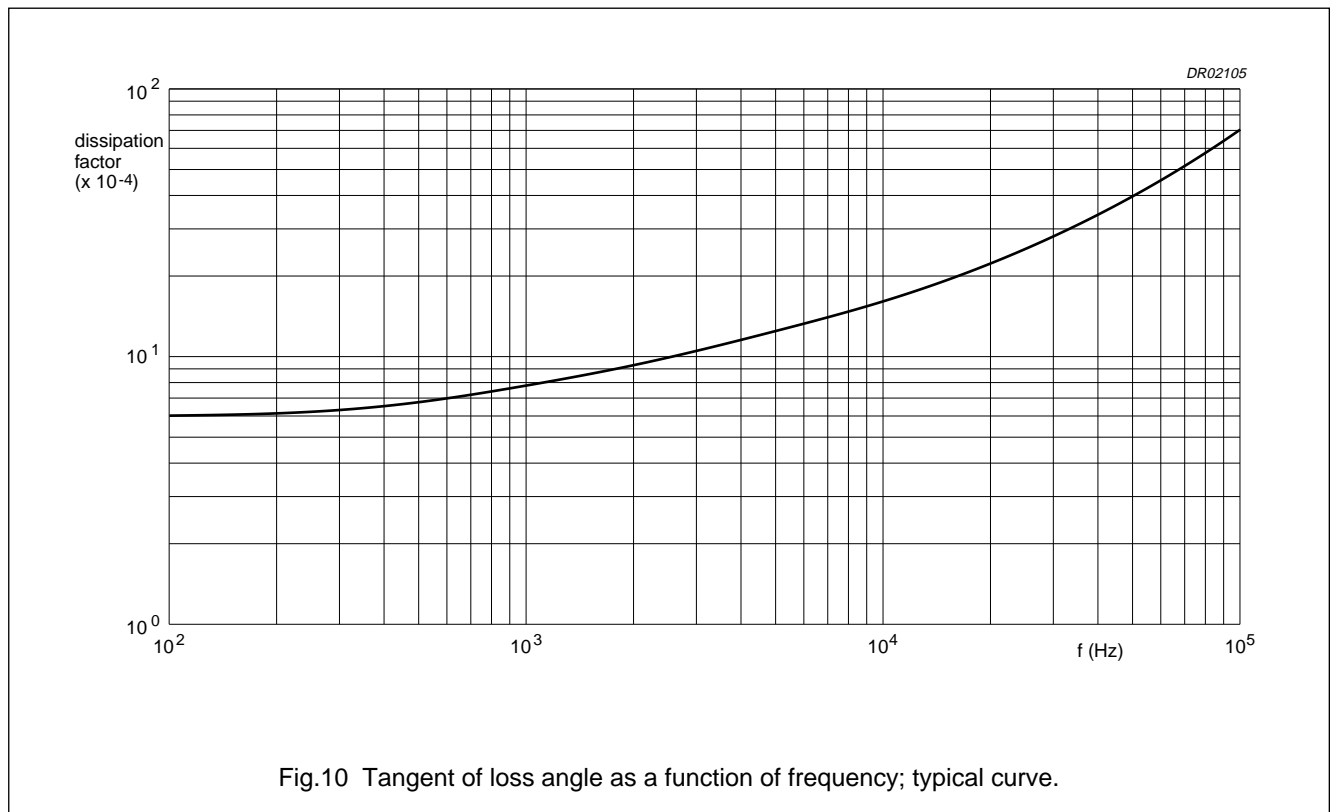

Fig.10 Tangent of loss angle as a function of frequency; typical curve.

Temperature

- Storage temperature: $T_{\text{stg}} = -25 \text{ }^\circ\text{C}$ to $+40 \text{ }^\circ\text{C}$ with RH maximum 80% without condensation.

Voltage

- Category voltage: $U_c = 0.8 \times U_{\text{Rdc}}$
- Test voltage between leads: $1.6 \times U_{\text{Rdc}}$
- Test voltage between interconnected leads and case (foil method): $2 \times U_{\text{Rdc}}$ (min. 200 V).

Metallized Polycarbonate film capacitors

MKC 344

Rated voltage pulse slope (dU/dt)_R

RATED VOLTAGE U _R (V)	MAXIMUM RATED PULSE LOAD (V/μs) ⁽¹⁾⁽²⁾			
	P = 10.0 mm	P = 15.0 mm	P = 22.5 mm	P = 27.5 mm
100	60	26	12	9
250	90	36	16	14
400	140	60	26	22
630	200	90	36	30

Notes

1. The maximum pulse load values are valid for voltages equal to the rated voltage. For lower voltages the given values may be multiplied by U_{Rdc} and divided by the applied voltage.
2. If the pulse requirement is satisfied, a check must be made to ensure that the maximum dissipation is not exceeded.

Insulation resistance

The insulation resistance is measured after a voltage has been applied for 1 minute ±5 seconds, the voltage being 100 ±15 V for the 100, 250 and 400 V versions and 500 ±50 V for the 630 V version:

- R between leads for C ≤ 0.33 μF: >30000 MΩ
- RC between leads for C > 0.33 μF: >10000 s
- R between interconnected leads and case (foil method): >30000 MΩ.

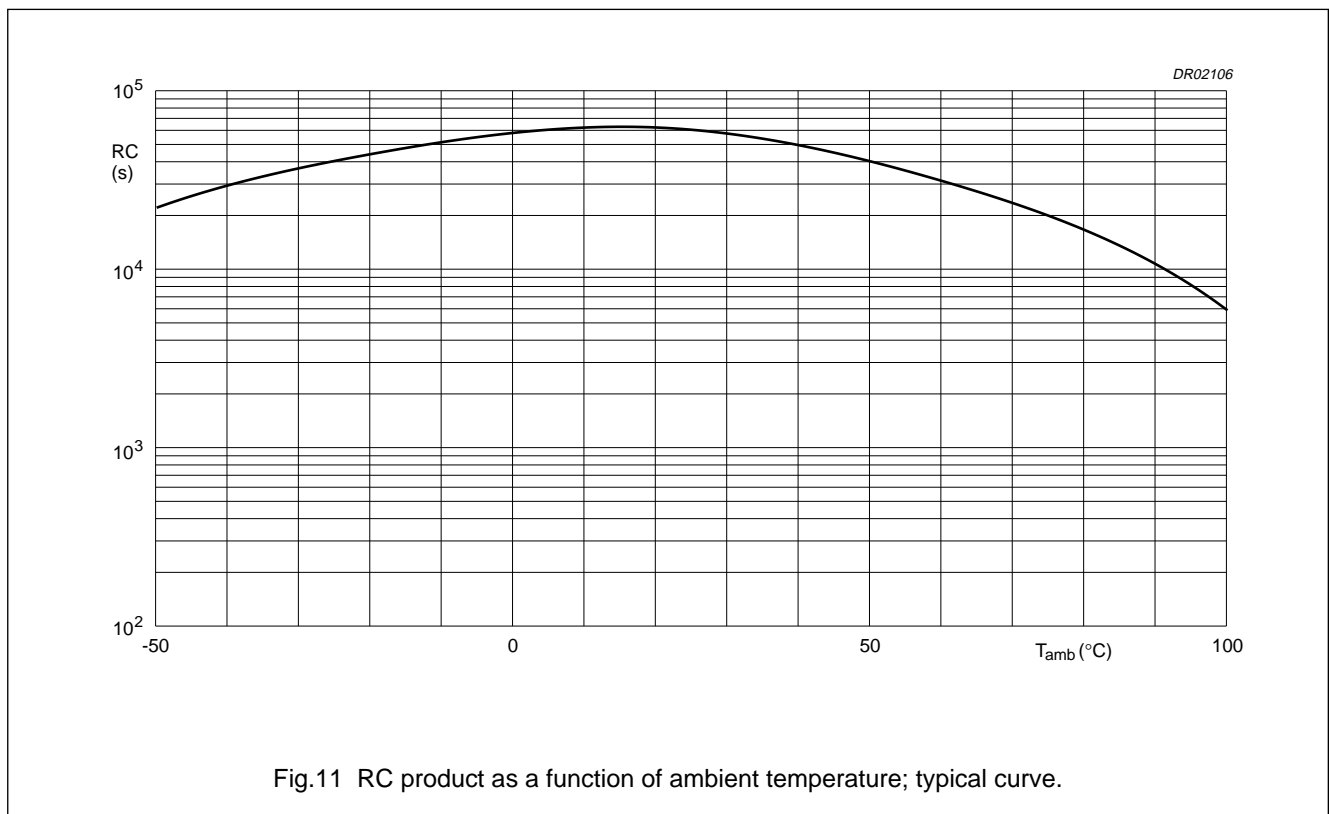

Fig.11 RC product as a function of ambient temperature; typical curve.

Metallized Polycarbonate film capacitors

MKC 344

Maximum dissipation

Power dissipation curves as a function of pitch and capacitor thickness (see Figs 12 and 13)

b _{max} (mm)	PITCH (mm)			
	10	15	22.5	27.5
4.0	1	–	–	–
5.0	2	4	–	–
6.0	3	5	8	–
7.0	–	6	9	–
8.5	–	7	10	–
9.0	–	–	–	12
10.0	–	–	11	–
11.0	–	–	–	13
13.0	–	–	–	14

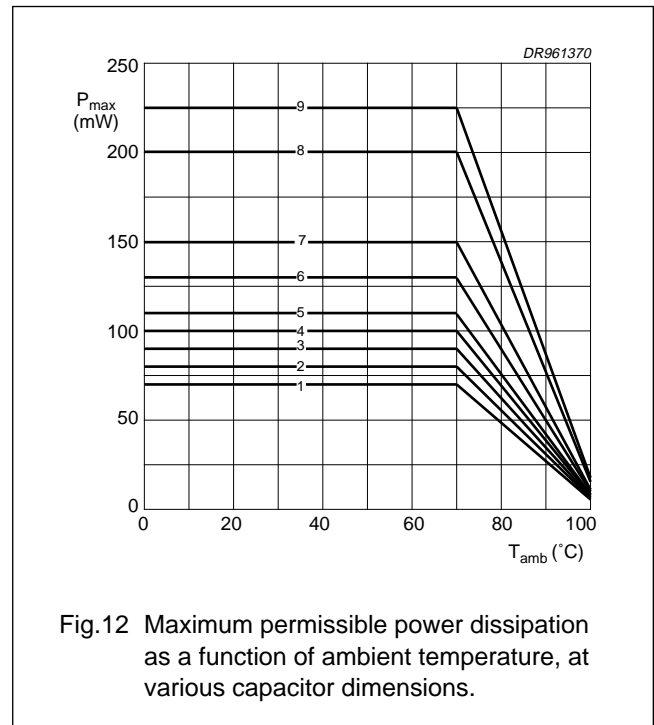

Fig.12 Maximum permissible power dissipation as a function of ambient temperature, at various capacitor dimensions.

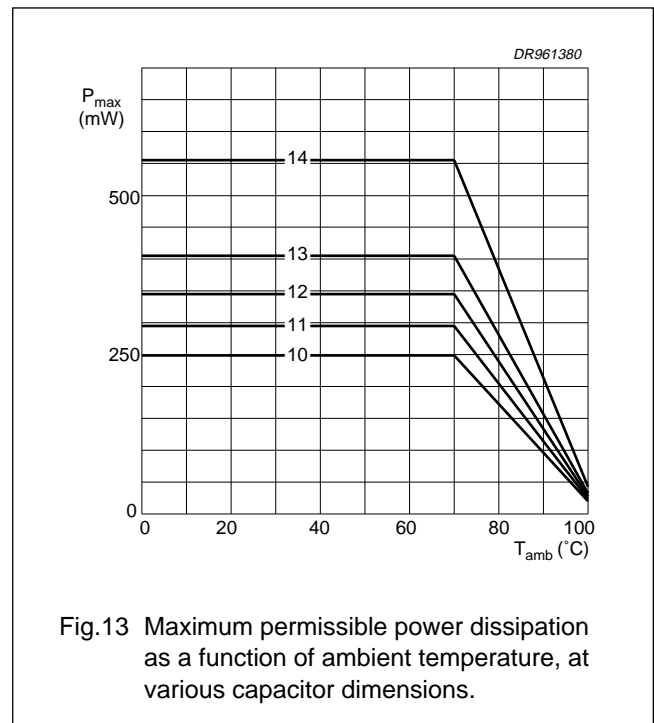

Fig.13 Maximum permissible power dissipation as a function of ambient temperature, at various capacitor dimensions.

Metallized Polycarbonate film capacitors

MKC 344

Application note

To select the capacitor for a certain application, the following conditions must be checked:

1. The peak voltage (U_p) shall not be greater than the rated DC voltage (U_{Rdc}).
2. The peak-to-peak voltage (U_{p-p}) shall not be greater than $2 \times \sqrt{2}$ times the rated AC voltage (U_{Rac}) to avoid the ionisation inception level.
3. The peak current (I_p) shall not exceed the maximum peak current, defined as maximum voltage pulse slope (dU/dt) multiplied by the capacitance:

$$I_{p\max} = C \left(\frac{dU}{dt} \right)_{\max}$$

Or the voltage pulse slope shall not exceed the rated voltage pulse slope. If the pulse voltage is lower than the rated voltage, the values (see Section "Rated voltage pulse slope (dU/dt)R" for more details) may be multiplied by U_{Rdc} and divided by the applied voltage.

4. The dissipated power shall not be greater than the maximum permissible power dissipation stated in Figs 12 and 13.
5. The free air ambient temperature for the capacitor does not exceed the category temperature.
6. Since all metallized polycarbonate film capacitors have an intrinsically active flammability risk after a capacitor breakdown (short circuit), it is recommended that the power to the component is limited to 10 times the maximum allowed power dissipation (P_{\max}) during the short circuit failure mode of the capacitor.

MARKING**Product marking**

CAPACITORS WITH PITCH 10 mm

The capacitors are marked by laser print on the top with the following information:

1. Rated capacitance code in accordance with "IEC 62":
 $n = nF$; $\mu = \mu F$
2. Tolerance on rated capacitance: K = $\pm 10\%$; J = $\pm 5\%$;

and on the side with the following information:

1. Year and week of manufacture (e.g. 9110)
2. Rated voltage (DC) (e.g. 100 V)
3. Code for dielectric material (MKC)
4. Code for factory of origin (HQ)
5. Manufacturer's type designation (344)
6. Manufacturer (PH).

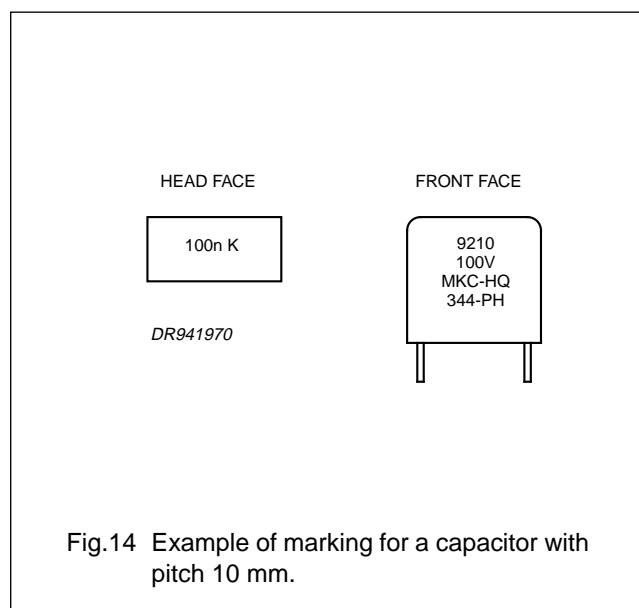

Fig.14 Example of marking for a capacitor with pitch 10 mm.

Metallized Polycarbonate film capacitors

MKC 344

CAPACITORS WITH PITCH 15 mm

The capacitors are marked by laser print on the top with the following information:

1. Rated capacitance code in accordance with "IEC 62":
n = nF; μ = μ F
2. Tolerance on rated capacitance: K = $\pm 10\%$; J = $\pm 5\%$
3. Rated voltage (DC) (e.g. 400 V)
4. Manufacturer's type designation (344)
5. Code for dielectric material (MKC);

and on the side with the following information:

1. Manufacturer
2. Code for factory of origin (HQ)
3. Year and week of manufacture (e.g. 9210).

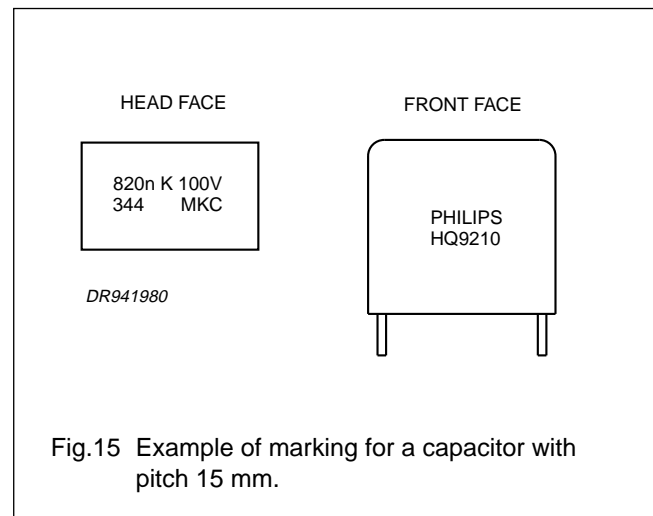

Fig.15 Example of marking for a capacitor with pitch 15 mm.

CAPACITORS WITH PITCH 22.5 OR 27.5 mm

The capacitors are marked by laser print on the top with the following information:

1. Rated capacitance code in accordance with "IEC 62":
n = nF; μ = μ F
2. Tolerance on rated capacitance: K = $\pm 10\%$; J = $\pm 5\%$
3. Rated voltage (DC) (e.g. 100 V)
4. Manufacturer.
5. Manufacturer's type designation (344)
6. Code for dielectric material (MKC)
7. Code for factory of origin (HQ)
8. Year and week of manufacture (e.g. 9210).

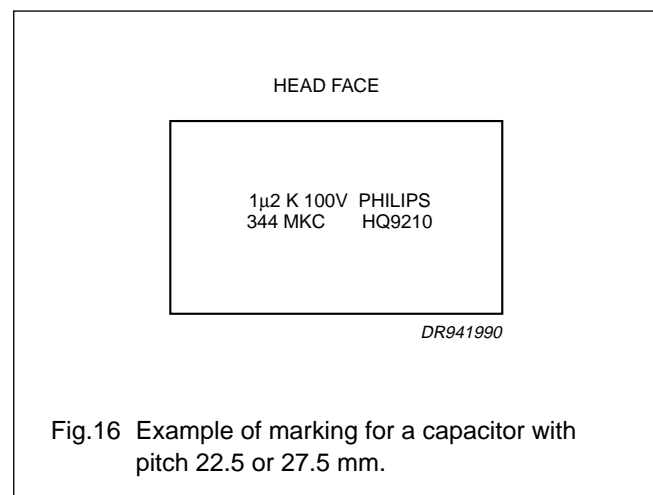

Fig.16 Example of marking for a capacitor with pitch 22.5 or 27.5 mm.

Metallized Polycarbonate film capacitors

MKC 344

Package marking

The package containing the capacitors is marked as shown in Fig.17.





<ol style="list-style-type: none"> 1. PHILIPS COMPONENTS 2. MADE IN BELGIUM 3. METAL. POLYCARB. FILM CAPACITOR 4. MKC RADIAL POTTED TYPE 5. 1μF \pm10% 250V= 55/100/56 6. 7.  WO: 12345678 ORIG A170 RPC HQ 1234 8.  TYPE MKC 344 9.  QTY 200 DATE 9625 10.  CODENO 2222 344 45105 <p style="text-align: right; font-size: small;">CCA324</p>	<p>Barcode label explanation</p> <table border="1"> <thead> <tr> <th>LINE</th> <th>MARKING EXPLANATION</th> </tr> </thead> <tbody> <tr> <td>1</td> <td>Manufacturer's name</td> </tr> <tr> <td>2</td> <td>Country of origin</td> </tr> <tr> <td>3</td> <td>Sub-family</td> </tr> <tr> <td>4</td> <td>Type description</td> </tr> <tr> <td>5</td> <td>Capacitance value, tolerance, voltage and climatic category ("IEC 68-1")</td> </tr> <tr> <td>6</td> <td>-</td> </tr> <tr> <td>7</td> <td>Preference origin code: A Country of origin in code: 170 (Belgium) Responsible production centre: HQ Work order: WO Wage number of final inspection. (only for 4e products)</td> </tr> <tr> <td>8</td> <td>Product type description</td> </tr> <tr> <td>9</td> <td>Quantity and production period, year and week code</td> </tr> <tr> <td>10</td> <td>Product code (12NC)</td> </tr> </tbody> </table>	LINE	MARKING EXPLANATION	1	Manufacturer's name	2	Country of origin	3	Sub-family	4	Type description	5	Capacitance value, tolerance, voltage and climatic category ("IEC 68-1")	6	-	7	Preference origin code: A Country of origin in code: 170 (Belgium) Responsible production centre: HQ Work order: WO Wage number of final inspection. (only for 4e products)	8	Product type description	9	Quantity and production period, year and week code	10	Product code (12NC)
LINE	MARKING EXPLANATION																						
1	Manufacturer's name																						
2	Country of origin																						
3	Sub-family																						
4	Type description																						
5	Capacitance value, tolerance, voltage and climatic category ("IEC 68-1")																						
6	-																						
7	Preference origin code: A Country of origin in code: 170 (Belgium) Responsible production centre: HQ Work order: WO Wage number of final inspection. (only for 4e products)																						
8	Product type description																						
9	Quantity and production period, year and week code																						
10	Product code (12NC)																						

Fig.17 Barcode label.

Metallized Polycarbonate film capacitors

MKC 344

QUICK REFERENCE TEST REQUIREMENTS (see note 1)

TEST	PROCEDURE (quick reference)	REQUIREMENTS
Robustness of leads		
Tensile and bending: "IEC 68-2-21"		no visible damage legible marking
Resistance to soldering heat: "IEC 68-2-20"	solder bath: 260 °C; 10 s	$ \Delta C/C \leq 1\%$
Component solvent resistance	isopropyl alcohol: 23 °C; 5 minutes	$\Delta \tan \delta \leq 30 \times 10^{-4}$; note 2
Robustness of component		
Vibration: "IEC 68-2-6"	10 to 55 Hz; amplitude 0.75 mm or acceleration 98 m/s ² ; 6 hours	$ \Delta C/C \leq 2.5\%$
Shock: "IEC 68-2-27"	half sinewave; 490 m/s ² ; 11 ms	$\Delta \tan \delta \leq 30 \times 10^{-4}$; note 2
Climatic sequence		
Dry heat: "IEC 68-2-2"	16 hours; 100 °C	$ \Delta C/C \leq 3\%$
Damp heat cyclic, test Db, first cycle: "IEC 68-2-30"		$\Delta \tan \delta \leq 50 \times 10^{-4}$; note 2
Cold: "IEC 68-2-1"	2 hours; -55 °C	$R_{ins} \geq 50\%$ of specified value
Damp heat, cyclic, test Db, remaining cycles: "IEC 68-2-30"		
Other applicable tests		
Damp heat steady state: "IEC 68-2-3"	56 days; 40 °C; 90 to 95% RH	$ \Delta C/C \leq 3\%$
		$\Delta \tan \delta \leq 50 \times 10^{-4}$; note 2
		$R_{ins} \geq 50\%$ of specified value
Endurance (DC): "IEC 384-6"	2000 hours; 1.25 × U _{Rdc} ; 85 °C 1.25 × U _{Cdc} ; 100 °C	$ \Delta C/C \leq 3\%$
		$\Delta \tan \delta \leq 30 \times 10^{-4}$; note 2
		$R_{ins} \geq 50\%$ of specified value
Heat storage: "IEC 384-6"	2000 hours; 100 °C	$ \Delta C/C \leq 3\%$
		$\Delta \tan \delta \leq 30 \times 10^{-4}$; note 2
Resistance to soldering heat with preheating: "IEC 384-6"	body temperature: 80 °C; bath temperature: 260 °C; dwell time: 5 s	$ \Delta C/C \leq 1\%$
		$\Delta \tan \delta \leq 30 \times 10^{-4}$; note 2
Passive flammability: "IEC 695-2-2"	class C	no burning

Notes

1. For detailed information, see "Type specification".
2. Measuring frequency 10 kHz.